

FT146	BL140.480						n <sub>1MAX</sub> [ rpm ]
	48V						
	ir	n <sub>2MIN</sub> [ rpm ]			n <sub>2MAX</sub> [ rpm ]		
M <sub>2</sub> [Nm]		sf		M <sub>2</sub> [Nm]	sf		
18.8	16.0	25	3.7	160	25	2.5	3000
26.2	11.5	34	2.7	115	34	1.8	
28.3	10.6	37	2.5	106	37	1.7	
35.1	8.6	46	2.5	86	46	1.7	
39.4	7.6	53	2.2	76	53	1.5	
46.4	6.5	61	1.9	65	61	1.3	
52.9	5.7	70	1.7	57	70	1.1	
60.6	4.9	80	1.6	49	80	1.1	
70.0	4.3	92	1.4	43	92	0.9	
84.6	3.5	111	1.1	35	111	0.8	
95.6	3.1	126	1.0	31	122	0.7	
113.4	2.6	149	0.8	26	122	0.7	
133.4	2.2	158	0.8	22	122	0.7	
150.2	2.0	158	0.8	20	122	0.7	
160.4	1.9	170	0.8	19	134	0.7	
178.8	1.7	170	0.8	17	134	0.7	
223.9	1.3	170	0.8	13	134	0.7	
236.8	1.3	170	0.8	13	134	0.7	
300.1	1.0	170	0.8	10	134	0.7	
397.4	0.8	170	0.8	7.5	134	0.7	

Attenzione: superamento della coppia nominale supportata dal riduttore per servizio S1. Contattare il ns. servizio tecnico  
Attention: rated torque withstood by gear reducer for service in S1 is exceeded. Please, contact our technical office.

Tipo Type	Numero di poli Number of poles	Numero di fasi Number of phase	Tensione Rated voltage [ V ]	Numero di giri Rated speed [ rpm ]	Coppia nominale Rated torque [ Nm ]	Potenza nominale Rated power [ W ]
BL140.480	8	3	48	3000	1.4	440
Tipo Type	Coppia massima Peak torque [ Nm ]	Corrente nominale Rated current [ A ]	Resistenza Resistance [ ohm ]	Induttanza Inductance [ mH ]	Corrente massima Peak current [ A ]	Peso Weight [ kg ]
BL140.480	2.8	13.0	0.16	0.5	26	3.15

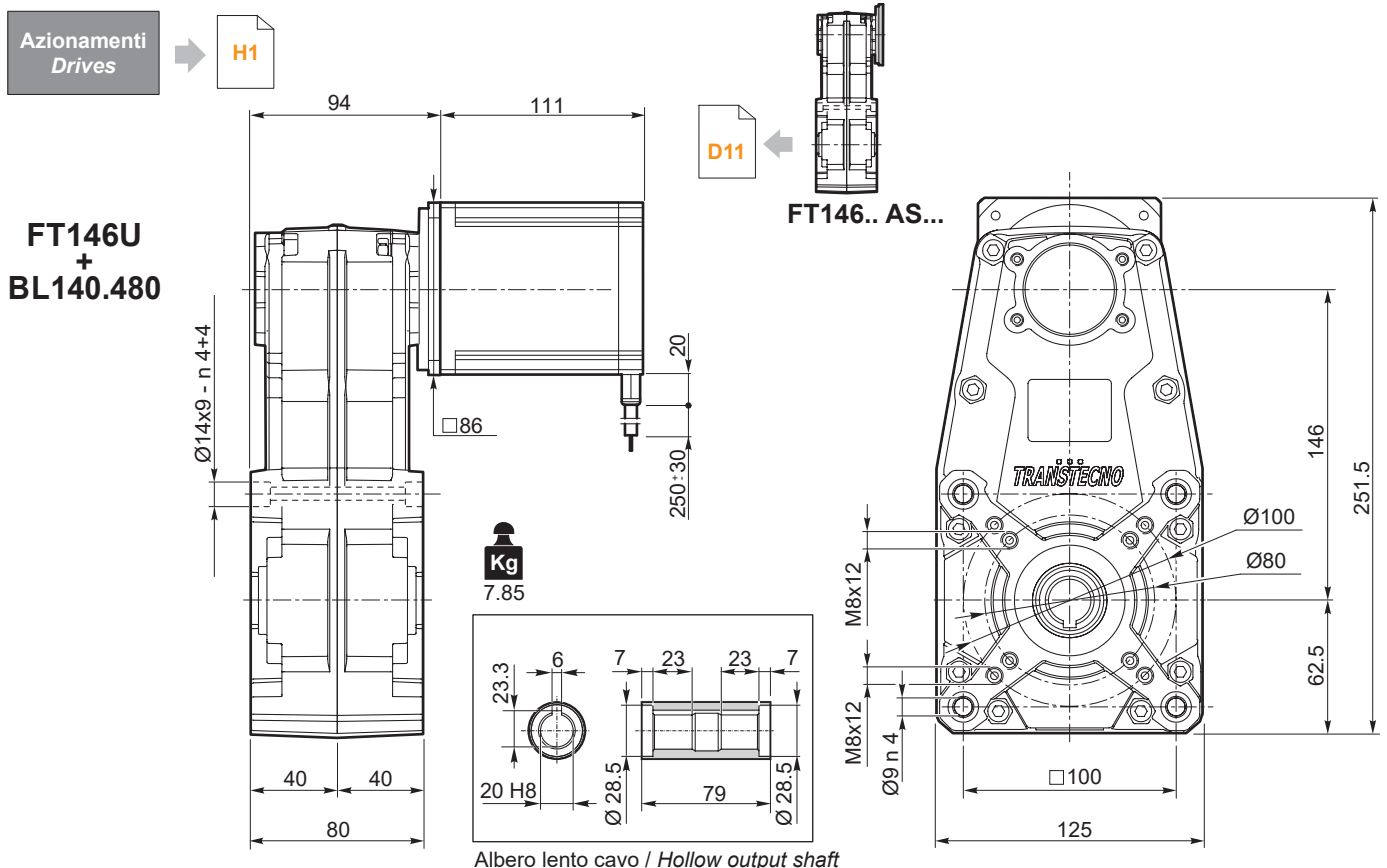

Brushless DC  
FT