

BL210.480 / BL210.48E

Dimensioni

Dimensions

BL210.480

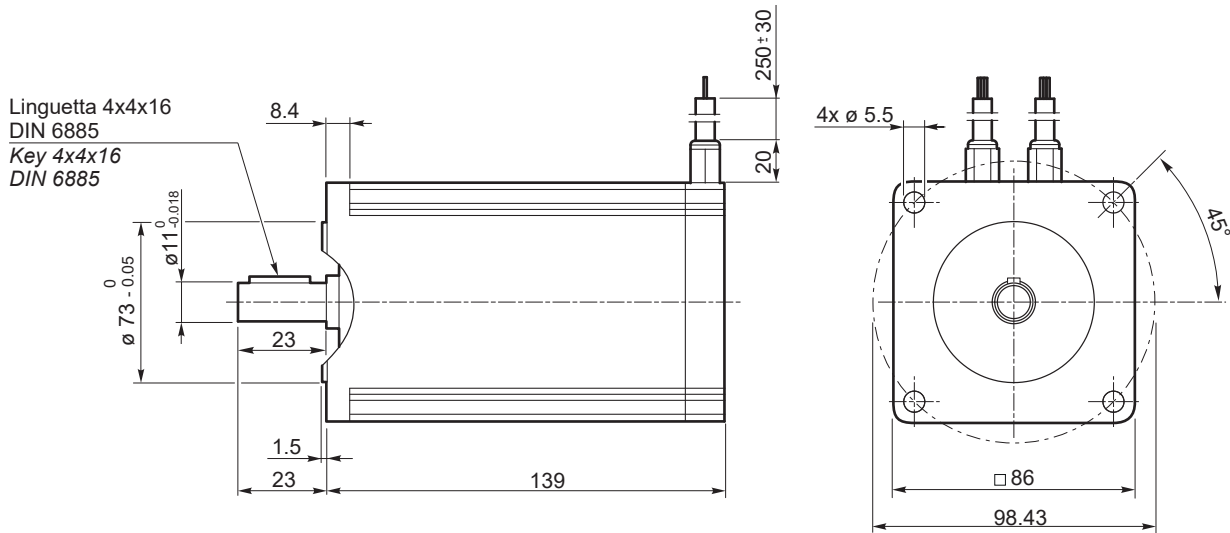

BL210.48E



Diagramma dei collegamenti

Connection diagram

| Cavi di potenza Power leads | Descrizione Description |
|--------------------------------|----------------------------|
| Blu / Blue | Fase U / U motor Phase |
| Marrone / Brown | Fase V / V motor Phase |
| Nero / Black | Fase W / W motor Phase |

| Cavi di segnale Signal leads | Descrizione Description |
|---------------------------------|---|
| Blue | HALL fase U U phase HALL |
| Verde Green | HALL fase V V phase HALL |
| Bianco White | HALL fase W W phase HALL |
| Rosso (piccolo) Red (small) | Alimentazione HALL + 5Vcc Supply voltage for Hall sensors, + 5 Vdc |
| Nero (piccolo) Black (small) | Comune per i segnali di HALL Ground for HALL sensors |

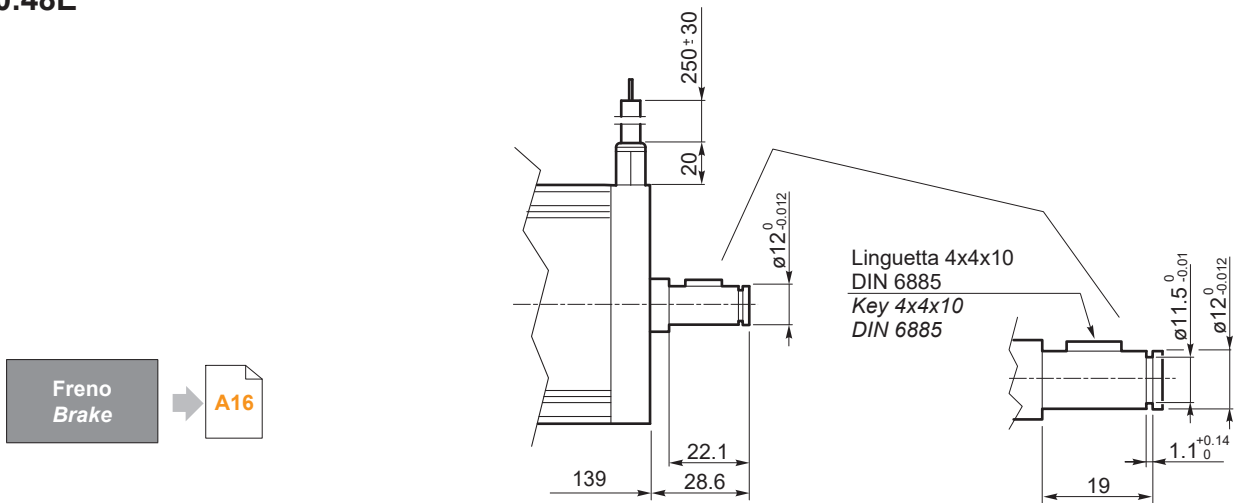
Nota: Si raccomanda di seguire fedelmente gli schemi di collegamento qui riportati, pericolo di danneggiamento del motore o dell'elettronica.

Note: Pls, follow strictly the above connection diagrams, danger for the motor and the electric control